

● General Description

It combines advanced trench MOSFET technology with a low resistance package to provide extremely low $R_{DS(ON)}$.

● Features

- Low $R_{DS(ON)}$ to minimize conductive loss
- Low Gate Charge for fast switching
- Low thermal resistance
- AEC-Q101 qualified

● Application

- BLDC motor driver
- DC-DC
- Load switch



● Product Summary

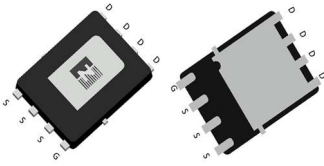

DSCQFN5*6

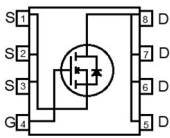

$V_{DS}=60V$

$R_{DS(ON)}=1.25m\Omega$

$I_D=223A$



● Ordering Information

Part NO.	ZMSA012N06HNCD
Marking	ZMS012N06H
Packing information	REEL TAPE
Basic ordering unit (pcs)	3000

● Absolute Maximum Ratings ($T_A=25^\circ C$, unless otherwise specified)

Parameter	Symbol	Conditions	Min.	Max.	Unit
Drain-source voltage	V_{DS}		-	60	V
Gate-source voltage ^①	V_{GS}		-20	20	V
Continuous drain current	I_D	$V_{GS}=10V, T_C=25^\circ C$	-	223	A
	I_D	$V_{GS}=10V, T_C=75^\circ C$	-	184	A
	I_D	$V_{GS}=10V, T_C=100^\circ C$	-	160	A
Pulsed drain current	I_{DM}	Pulsed; $t_p \leq 10 \mu s$; $T_C = 25^\circ C$;	-	669	A
Diode continuous current	I_S	$V_{GS}=0V, T_C=25^\circ C$	-	135	A
Diode pulse current	$I_{S,pulse}$	$V_{GS}=0V$, Pulsed, $t_p \leq 10 \mu s$, $T_C = 25^\circ C$	-	540	A
Total power dissipation	P_D	$T_C=25^\circ C$	-	176	W
Total power dissipation	P_D	$T_A=25^\circ C$	-	3.3	W
Operating junction temperature	T_J		-55	175	$^\circ C$
Storage temperature	T_{STG}		-55	175	$^\circ C$
Single pulse avalanche energy	E_{AS}	$L=0.1mH, V_{GS}=10V, R_g=25\Omega$,	-	320	mJ

		L=0.5mH, V _{GS} =10V, R _g =25Ω,	-	672	mJ
ESD level (HBM)			CLASS 2		

● Thermal resistance

Parameter	Symbol	Min.	Typ.	Max.	Unit
Thermal resistance, junction - case	R _{thJC}	-	-	0.85	°C/W
Thermal resistance, junction - ambient	R _{thJA} ^②	-	-	45	°C/W
Soldering temperature	T _{sold}	-	-	260	°C

● Electronic Characteristics (T_j=25°C, unless otherwise specified)

Parameter	Symbol	Condition	Min.	Typ.	Max.	Unit
Drain-source breakdown voltage	BV _{DSS}	V _{GS} =0V, I _D =250uA	60	-	-	V
Gate threshold voltage	V _{GS(th)}	V _{GS} =V _{DS} , I _D =250uA	2	2.7	4	V
Drain-source leakage current	I _{DSS}	V _{GS} =0V, V _{DS} =60V	-	-	1	uA
Gate- source leakage current	I _{GSS}	V _{GS} =±20V, V _{DS} =0V	-	-	100	nA
Static drain-source on resistance	R _{DS(ON)}	V _{GS} =10V, I _D =40A, T _j =25°C	-	1.25	1.65	mΩ
Forward transconductance	g _{FS}	V _{DS} =5V, I _{SD} = 10A	-	15	-	S
Diode forward voltage	V _{FSD}	V _{GS} =0V, I _{SD} = 40A	-	-	1.3	V

● Dynamic characteristics (T_j=25°C, unless otherwise specified)

Parameter	Symbol	Condition	Min.	Typ.	Max.	Unit
Input capacitance	C _{iss}	f = 1MHz, V _{DS} =25V, V _{GS} =0V	-	4950	-	pF
Output capacitance	C _{oss}		-	1800	-	pF
Reverse transfer capacitance	C _{rss}		-	72	-	pF
Gate resistance	R _g	f = 1MHz	-	1.6	-	Ω
Total gate charge	Q _g	V _{DD} = 15V, I _D = 20A, V _{GS} = 10V	-	67	-	nC
Gate-source charge	Q _{gs}		-	17	-	nC
Gate-drain charge	Q _{gd}		-	14	-	nC
Turn-on delay time	t _{D(on)}	V _{GS} =10V, V _{DS} =15V, R _G =3.3Ω, I _D =20A	-	15	-	ns
Turn-on rise time	t _r		-	10	-	ns
Turn-off delay time	t _{D(off)}		-	26	-	ns
Turn-off fall time	t _f		-	17	-	ns
Reverse recovery time	t _{rr}	V _{DD} =20V, dI _S /dt = 100A/us, I _S =50A	-	48	-	ns
Reverse recovery charge	Q _{rr}		-	47	-	nC

● Fig.1 Gate-source voltage as a function of gate charge; Typical values; $T_j=25^\circ\text{C}$

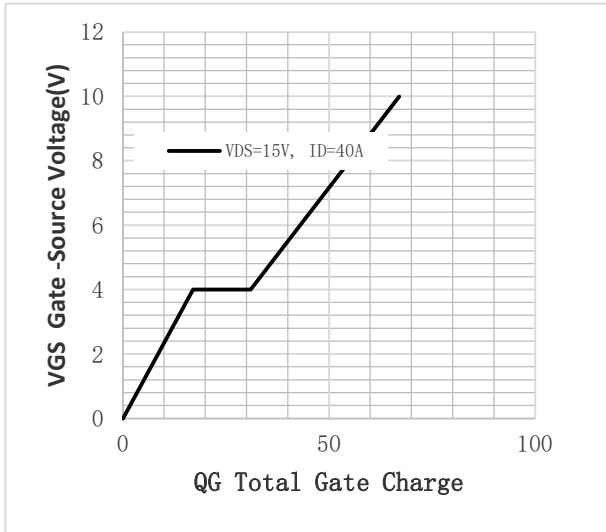

● Fig.2 Input, output and reverse transfer capacitances as a function of drain-source voltage; Typical values; $T_j=25^\circ\text{C}$

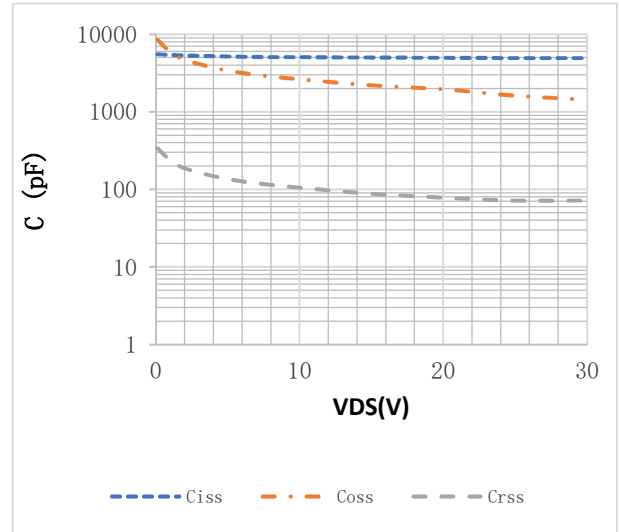

● Fig.3 Output characteristics: drain current as a function of drain-source voltage; Typical values; $T_j=25^\circ\text{C}$

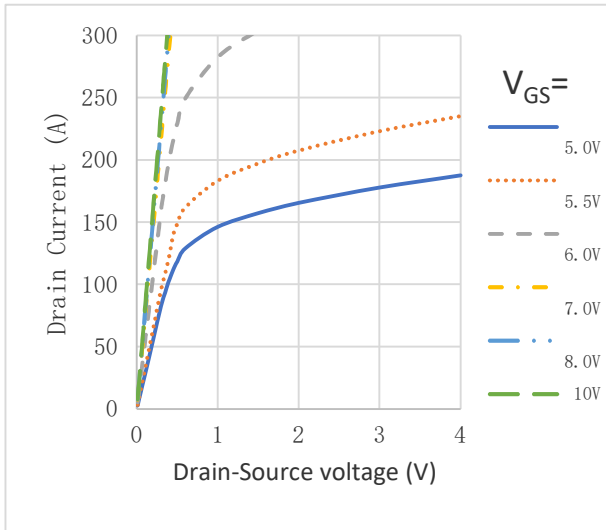

● Fig.4 Output characteristics: drain current as a function of drain-source voltage; Typical values: Expanded curve; $T_j=25^\circ\text{C}$

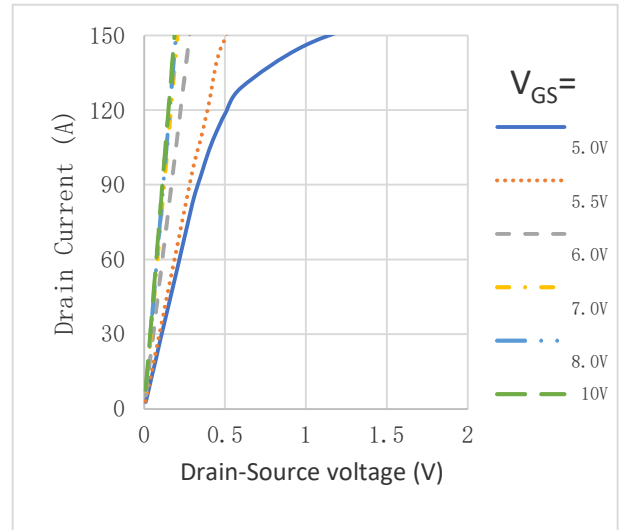

● Fig.5 Gate-source threshold voltage as a function of junction temperature; Typical values

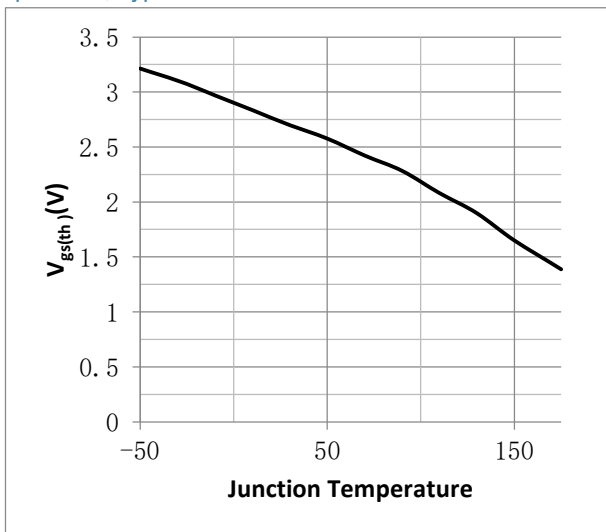

● Fig.6 Drain-source on-state resistance as a function of drain current; Typical values; $T_j=25^\circ\text{C}$

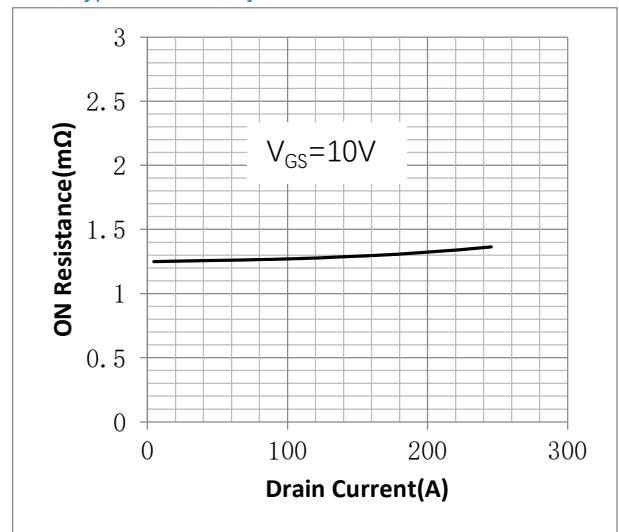

● Fig.7 Drain-source on-state resistance as a function of gate-source voltage; Typical values

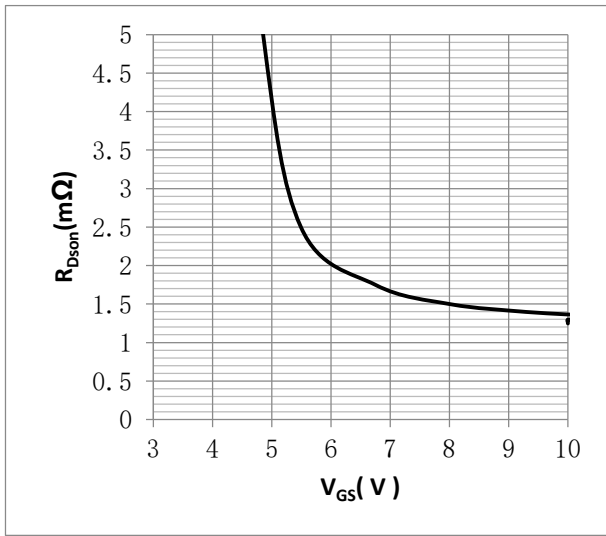

● Fig.8 Normalized drain-source on-state resistance factor as a function of junction temperature; Typical values Normalized On-Resistance= $R_{Dson}/R_{Dson}(25^\circ C)$

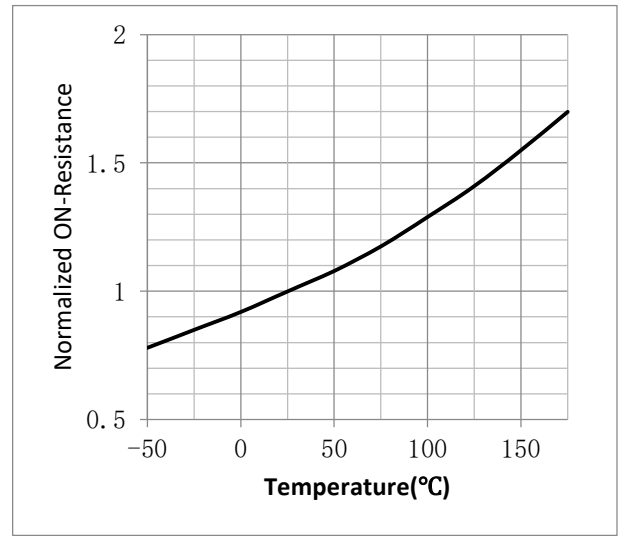

● Figure 9. Source (diode forward) current as a function of source-drain (diode forward) voltage; Typical values

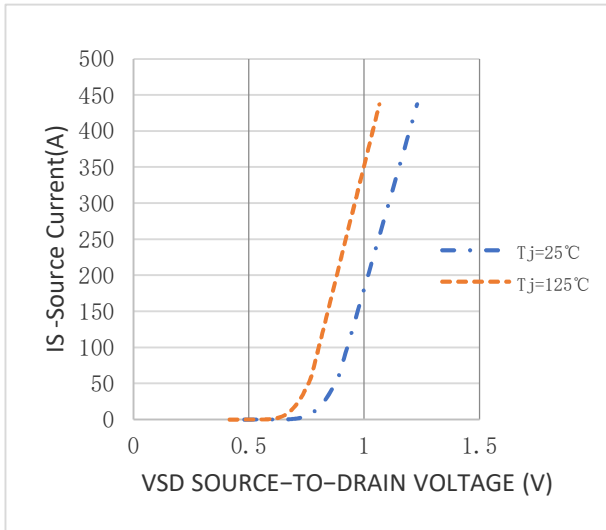

● Figure 10. Transfer characteristics: drain current as a function of gate-source voltage; Typical values

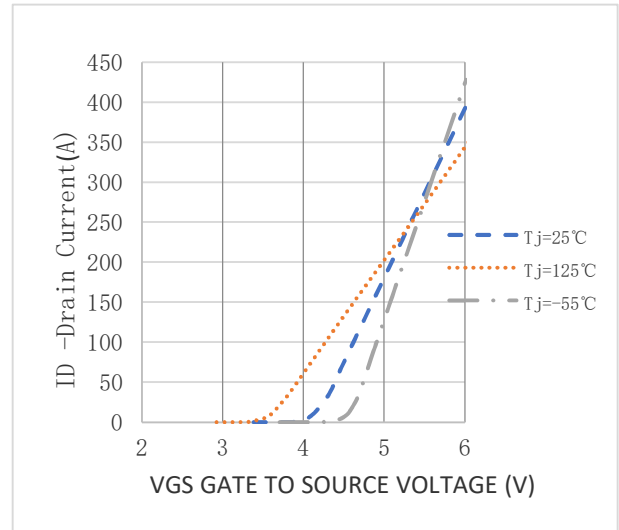

● Fig.11 Safe operating area: continuous and peak drain currents as a function of drain-source voltage; Calculative values

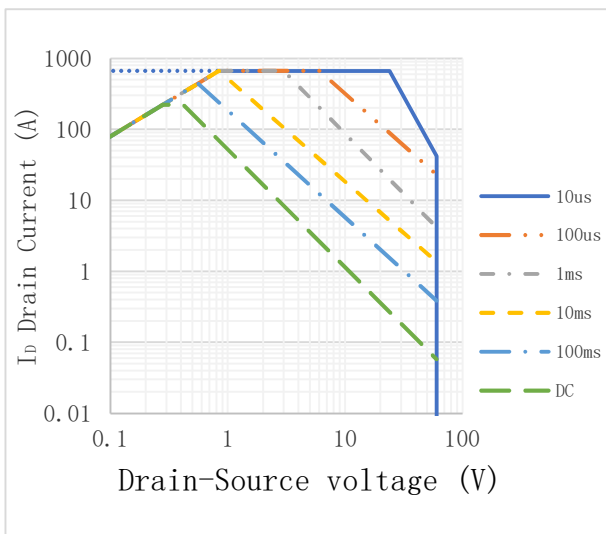

● Fig.12 Continuous drain current as a function of case temperature; Calculative values

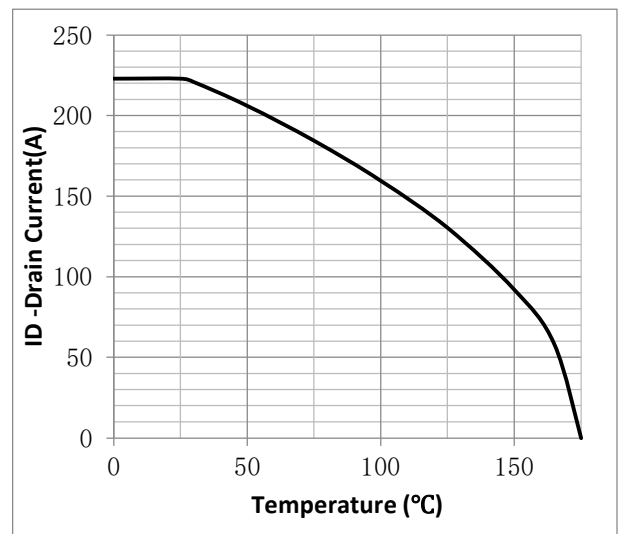

● Fig.13 Drain-source breakdown voltage as a function of junction temperature; Typical values Normalized $BV_{DSS} = BV_{DSS} / BV_{DSS}(25^{\circ}C)$

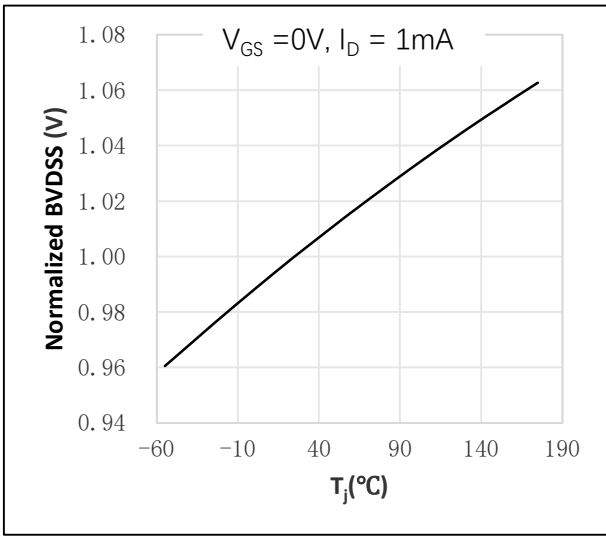

● Fig.14 Normalized total power dissipation as a function of case temperature; Calculative values Normalized Power Dissipation $= P_d / P_d(25^{\circ}C)$

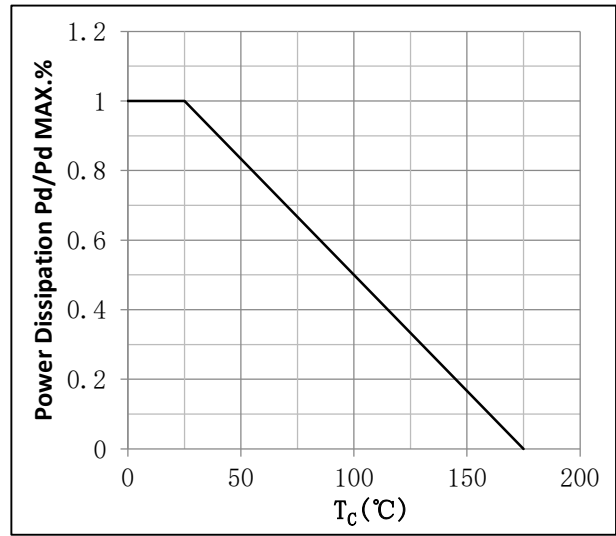

● Fig.15 Transient thermal impedance from junction to case as a function of pulse duration; max values

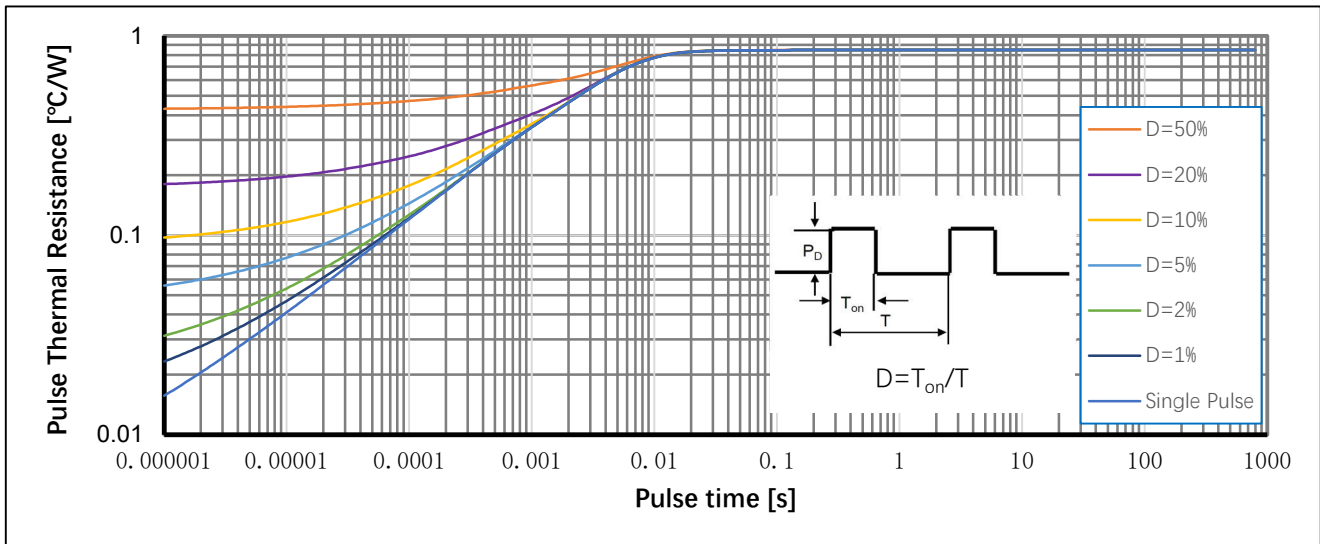

● Package Outline

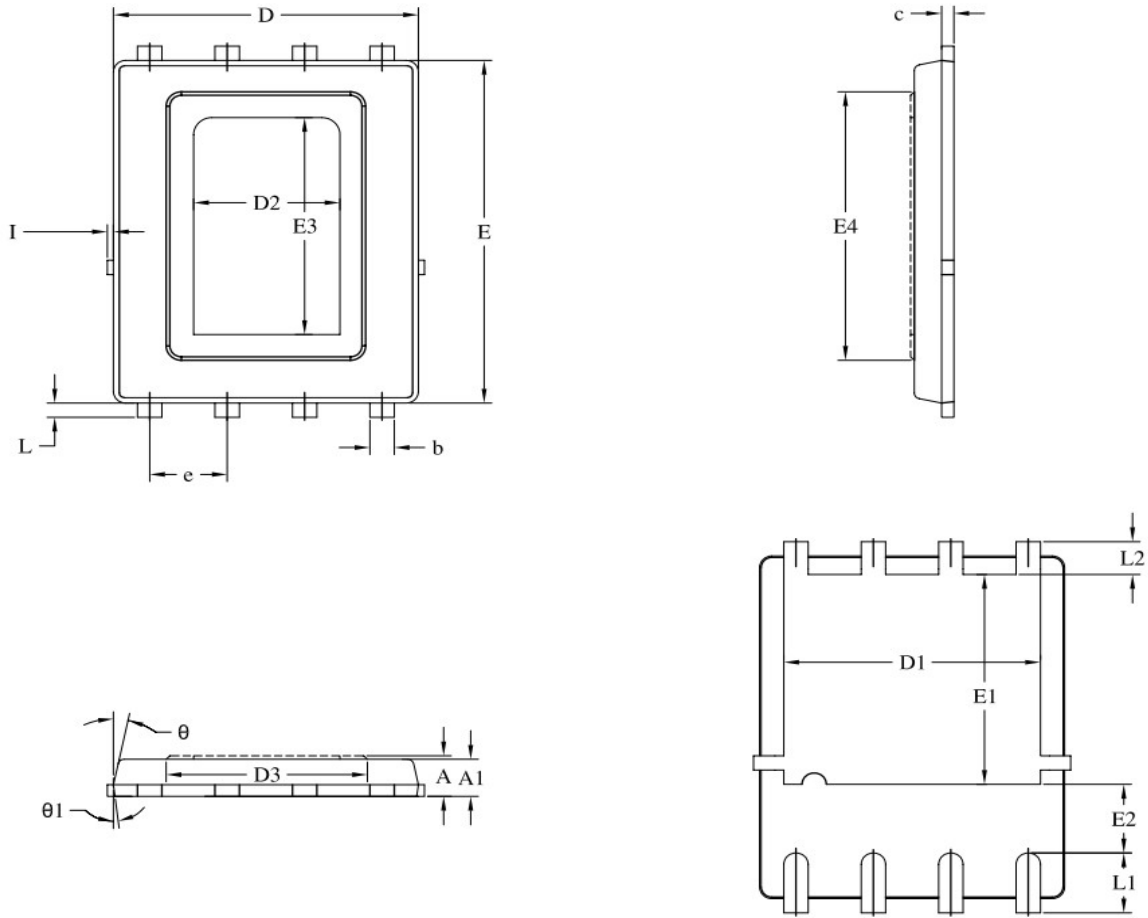

SYMBOL	COMMON		
	MIN.	Nom.	MAX.
A	0.660	0.710	0.760
A1	0.600	-----	0.750
b	0.330	0.430	0.530
c	0.150	0.203	0.300
D	5.00 Bsc.		
D1	4.060	4.210	4.360
D2	2.400 Bsc.		
D3	2.800	3.300	3.800
E	6.00 Bsc.		
E1	3.525	3.675	3.825
E2	1.050	1.200	1.350
E3	3.800 Bsc.		
E4	4.200	4.700	5.200
e	1.270 Bsc.		
I	-----	-----	0.150
L	0.150	0.250	0.350
L1	0.925	1.050	1.175
L2	0.450	0.575	0.700
θ	12° Bsc.		
$\theta 1$	7° Bsc.		

● Note

- ① Pulse : $V_{GS}=+20V/-20V$, Duty cycle=50%, $T_j=175^{\circ}C$, $t=1000$ hours; For DC , the following test conditions can be passed: $V_{GS}=+20V/-10V$, $T_j=175^{\circ}C$, $t=1000$ hours;
- ② Device mounted on 1 square inch FR-4 substrate PCB, 1oz copper, minimum footprint, tested in a still air environment with $T_A=25^{\circ}C$;
- ③ Practically the current will be limited by PCB, thermal design and operating temperature. $V_{GS}=10V$.

● Disclaimer

- Reproducing and modifying information of the document is prohibited without permission from ZMJ SEMICONDDUCTORS CO., LTD.
- ZMJ SEMICONDDUCTORS CO., LTD. reserves the rights to make changes of the content herein the document anytime without notification. Please refer to our website for the latest document.
- ZMJ SEMICONDDUCTORS CO., LTD. disclaims any and all liability arising out of the application or use of any product including damages incidentally and consequentially occurred.
- ZMJ SEMICONDDUCTORS CO., LTD. does not assume any and all implied warranties, including warranties of fitness for particular purpose, non-infringement and merchantability.
- Applications shown on the herein document are examples of standard use and operation. Customers are responsible in comprehending the suitable use in particular applications. ZMJ SEMICONDDUCTORS CO., LTD. makes no representation or warranty that such applications will be suitable for the specified use without further testing or modification.
- The products shown herein are not designed and authorized for equipments relating to human life and for any applications concerning life-saving or life-sustaining, such as medical instruments, aerospace machinery et cetera. Customers using or selling these products for use in such applications do so at their own risk and agree to fully indemnify ZMJ SEMICONDDUCTORS CO., LTD. for any damages resulting from such improper use or sale.
- Since ZMJ uses lot number as the tracking base, please provide the lot number for tracking when complaining.

● Revision History

Version	Date	Change
A	2023/8/12	New
B	2024/2/29	Correct ciss,Qg
C	2025/10/15	Apply new datasheet format.